

1 Type A Elevation  
0483

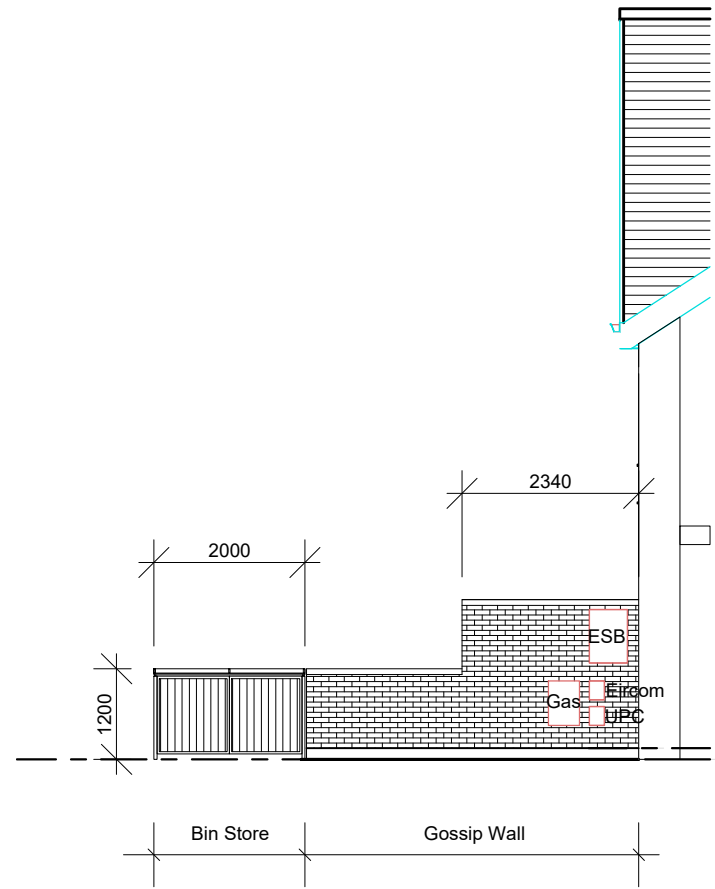

3 Type B Elevation  
0483

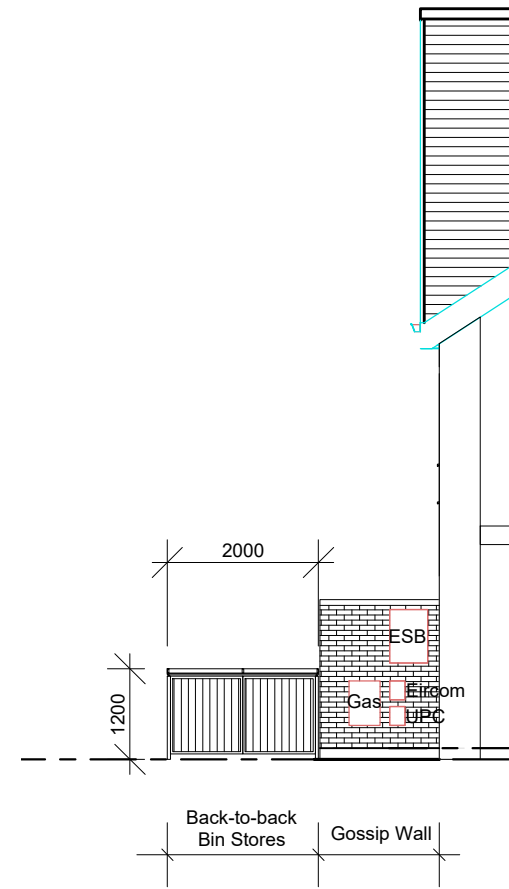

5 Type C Elevation  
0483

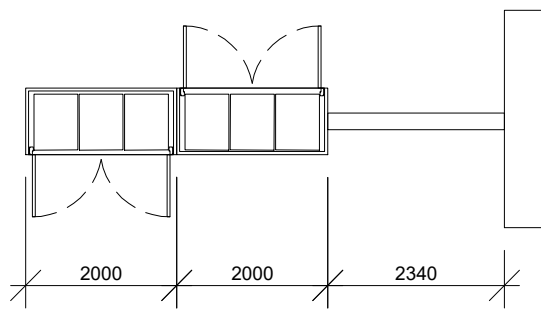

2 Type A Plan  
0483

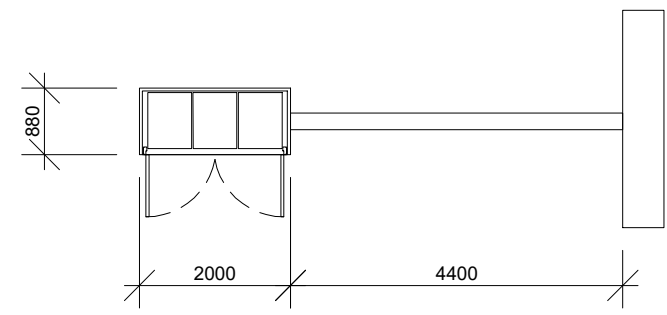

4 Type B Plan  
0483

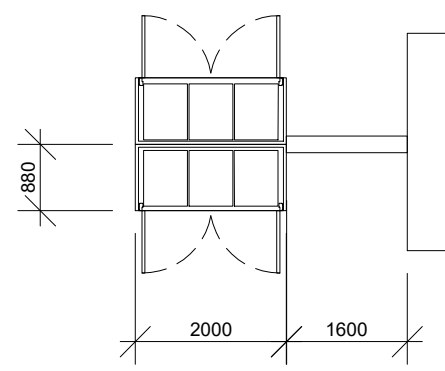

6 Type C Plan  
0483

TERRACED HOUSE BIN & BIKE STORES LOCATIONS  
 TYPE A ■  
 TYPE B ■  
 TYPE C ■



NOTES / LEGEND

NORTH POINTS AND LEVELS TO BE REFERENCED FROM SITE PLAN

Rev.	Date:	Description:	By:

**MOLA** 2 Donnybrook Road,  
 Donnybrook,  
 Dublin 4, Ireland  
 Telephone +353 1 218 3800  
 www.molaarchitecture.com

Notes  
 Do not scale.  
 Use figured dimensions only.  
 This drawing is to be read in conjunction with all relevant specifications and drawings.  
 All dimensions to be checked on site.  
 In the event of any discrepancies between drawings, the contractor is to inform the Architect immediately.  
 © COPYRIGHT This drawing or design may not be reproduced without permission

PLANNING			
Client:	Calm Homes Properties Ltd.		
Project:	Cookstown Road Enniskerry		
Drawing:	Terraced Houses Bin Stores Types A, B & C		
Date:	Feb 2021	Scale:	1:100 at A3
Sheet:	3	Int. Job No.:	19010
Drawing No.:	19010_MOLA_A00_00_DR_A_XX_A00_0483	Status:	SO
Revision:	00		